

# 1977 CHEVY VAN AND SPORTVAN



## Chevy Van

- Two wheelbases — 110" and 125".
- Three series — G10 (½ Ton), G20 (¾ Ton), G30 (1 Ton).
- GVWRs from 4800 to 8400 lbs.
- Up to 4160 lbs. or 296-cu.-ft. payload capacity.
- Convenient right side sliding side door.
- Two Six and three V8 engines available.



## Chevy Sportvan

- Two wheelbases — 110" and 125".
- Three series — G10 (½ Ton), G20 (¾ Ton), G30 (1 Ton — 125" WB only).
- GVWRs from 5400 to 8400 lbs.
- Seating for up to 12 (with available seats).
- Luxurious Beauville interior available (on 125" wheelbase models only).
- Two Six and three V8 engines available.

# 1977 CHEVY VAN/SPORTVAN

---

## NEW FOR 1977



### NOMAD

Personal use packages, Caravan and Nomad, for Chevy Van are new entries into this growing

segment of the van market • For more information see pages 4-7.



### CARAVAN



# 1977 CHEVY VAN/SPORTVAN

---

## NEW FOR 1977

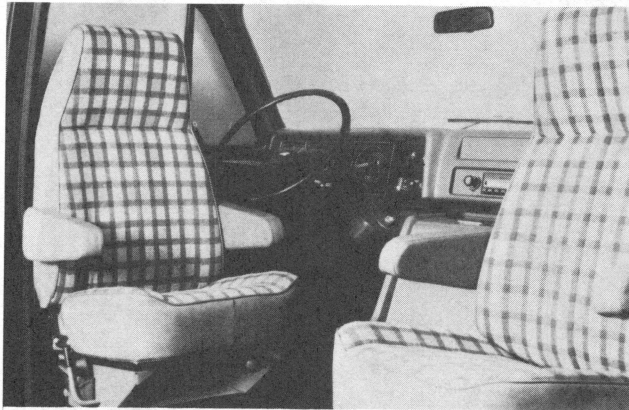

**Beauville trim** for Chevy Van front compartment area only • Includes high back cloth bucket seats and carpeting.

**Swivel bucket seats** in custom cloth or custom vinyl are available for the Nomad package and included in the Caravan package • (Will be introduced interim for Chevy Van and Sportvan.)

**New cloth trim** for the Beauville seats and swivel bucket seats.

**New wheel trim cover** available for G10-20 models • Replacing previous accessory wheel cover on these models is a black and chrome wheel cover in a spoked hub design.

**New spare tire covers** available • Black for G10 models and color-keyed for G20-30 models • Included equipment in Custom Package.

**Intermittent windshield wiper system** now available.

**Shock absorbers** have been revalved for improved ride characteristics • New 32mm shocks are available.

**New 305 2-bbl V8 engine** replaces 350-V8 2-bbl engine on G10 vehicles.

**New fuel tanks** have been designed to comply with FMVSS-301 • All optional fuel tanks have 33-gallon capacity.

**Sliding door mechanism** for latching and unlocking has been improved to provide greater ease of operation.



**Swing-out side door glass** in the sliding side door is now available for Chevy Vans.

**New paint and trim colors**—See pages 17 and 18.

**Rear springs** for G20-30 models with single rear wheels have a lower rate to provide an improved ride.

**New rear speaker** is incorporated into the right rear trim panel • Sportvan and Caravan only.

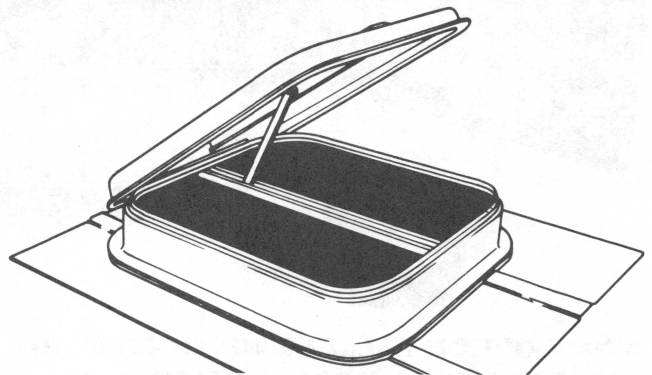

**Roof vent** in white, translucent plastic is included in the Caravan package • Available on Chevy Van, Sportvan and Nomad.



**Redesigned front fender and rear door nameplates.**

# 1977 CHEVY VAN CARAVAN



**A NEW OPTION PACKAGE WHICH GIVES THE VAN CUSTOMER A MORE COMPLETE BASE FOR HIS OWN CUSTOM TRIM.**

**MODELS: G10-20.**

Designed to provide custom van enthusiasts with a finished interior that they can use "as is" or as an under surface for custom work including carpeting, padding or other interior upholstery.

**The Caravan's rear cargo area** comes with a full-length plywood headliner • Walls, roof and upper half of the doors are insulated with thick fiberglass • Over this insulation is mounted attractive finished plywood paneling • A black rubber mat with insulation covers the floor • Inside rear door latch release • Insulation for rear wheel housings.

**The driver's area** features new swivel bucket seats • High back bucket seats are trimmed in a choice of durable custom vinyl or attractive cloth

and vinyl • Special color-keyed closing assist straps replace armrests for the front doors.

**A new 14" square translucent plastic roof vent** is also furnished • Vent is crank operated and includes a screen • Special Caravan nameplates replace the standard Chevy Van plates. Also Caravan nameplate on right rear door.

## **STANDARD SPECIFICATIONS.**

The Caravan is available on both the 110" and 125" wheelbase for the G10-20 Chevy Van.

## **Engines:**

G10

Standard: 250-6

Available: 305 V8; 350 V8

G20

Standard: 292-6

Available: 350 V8; 400 V8



# 1977 CHEVY VAN CARAVAN

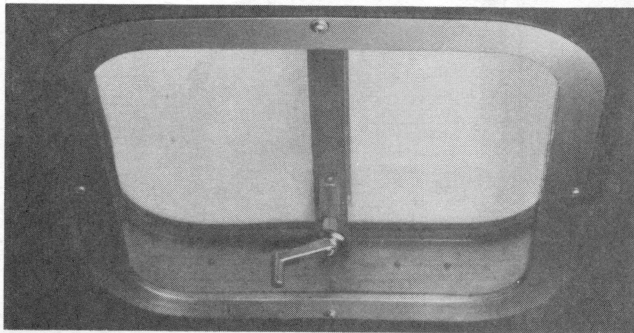

**Crank-operated white bubble-top roof vent** helps the air flow and offers illumination for the cargo area • Included in the Caravan package • Available on Chevy Van, Sportvan and Nomad.

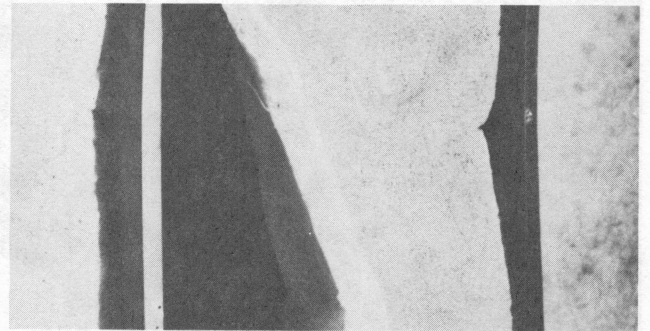

**Two inches of fiberglass insulation**, mounted between the body side braces, result in a quieter, more comfortable ride • Insulation on wheel-housings helps reduce road noise.

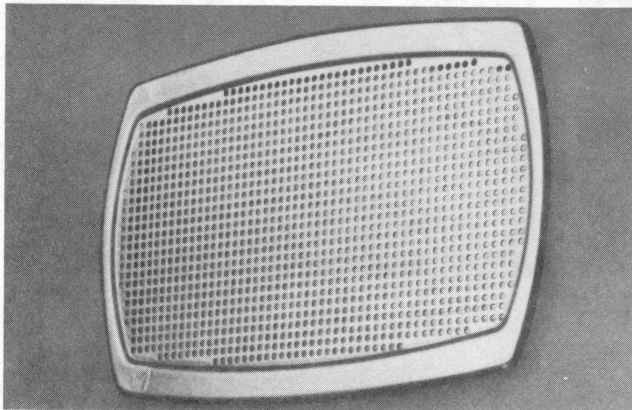

**Optional rear speaker** is mounted in the right rear plywood paneling above the wheelhousing.



**Full-length headliner** is made of plywood • Offers excellent sound insulation as well as a smooth, attractive appearance.

# 1977 CHEVY VAN NOMAD

**A NEW OPTION PACKAGE WHICH HELPS TURN A CHEVY VAN INTO AN EXCITING TRAVEL WAGON.**

**MODEL: G20.**

Designed for the customer who wants a spacious, comfortable passenger vehicle with an extra-large cargo area.

**Inside**, the Nomad features high back bucket seats up front plus a removable bench-type center seat

• Passenger area is finished off in rich Beauville trim with tough all-vinyl or attractive cloth-and-vinyl upholstery, cut-pile carpeting and woodtone accents on the door panels.

**The rear cargo area** comes with a color-keyed vinyl floor mat, full-length parchment-colored hard-board headliner with insulated foam backing and cargo tie-down provisions • Handy swing-out

windows on the right-hand sliding side door and left-hand wall are also included.

**Outside**, the Nomad features bright lower body side moldings; chromed grille, bumpers and hub-caps; windshield reveal moldings; special side-marker lights with bright trim and taillamp trim, plus Nomad nameplates.

**STANDARD SPECIFICATIONS.**

The Nomad is available on 125" wheelbase G20 Chevy Vans.

**Engines:** Standard—292 Six

Available—350 V8, 400 V8



**High back bucket seats** with Beauville cloth-and-vinyl trim are standard on Nomad • Swivel bucket seats are an available option.



# 1977 CHEVY VAN NOMAD



**Swing-out side windows** in both the sliding side door and opposite wall open quickly for increased ventilation.

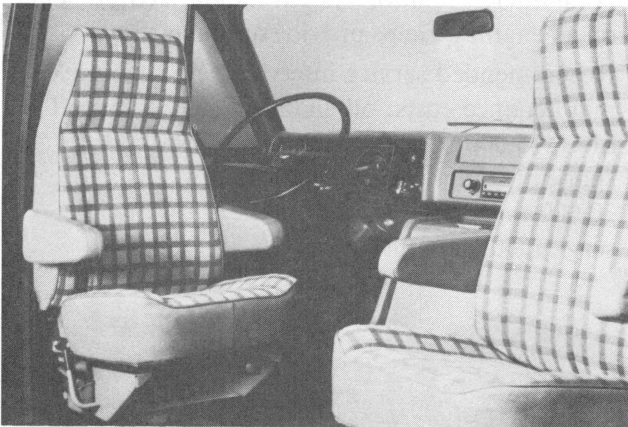

**Swivel bucket seats** in custom cloth are available for Nomad.

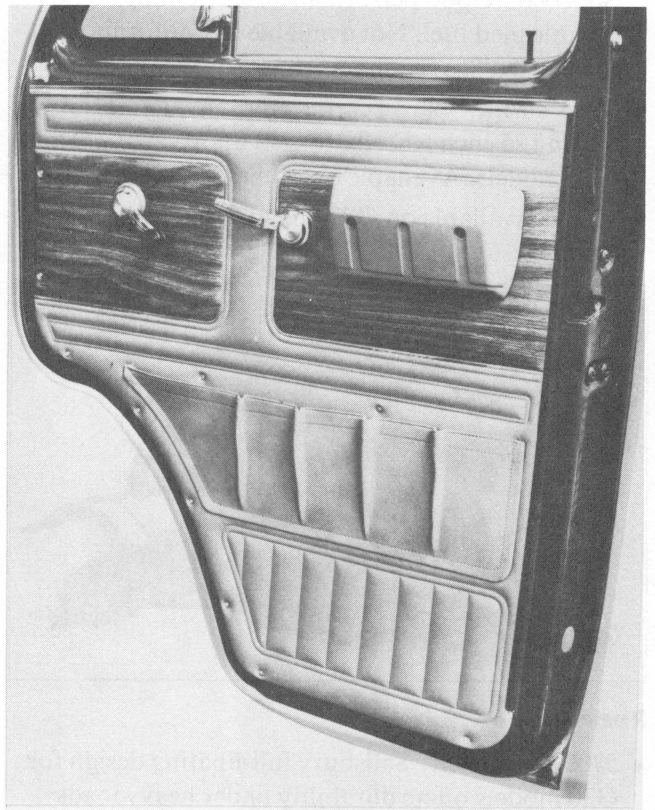

**Vinyl door panels with woodtone accents** combine the look of luxury with durability.

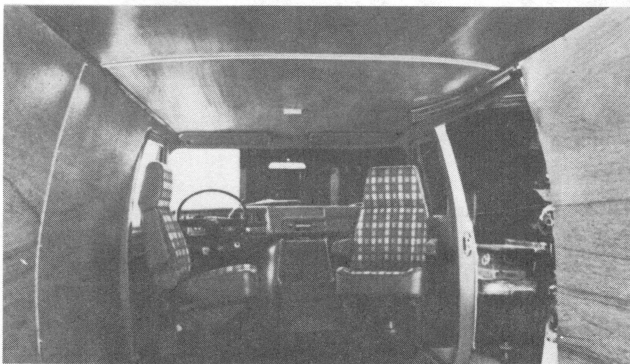

**Full-length headliner** offers excellent sound insulation as well as a smooth, attractive appearance.

# 1977 CHEVY VAN/SPORTVAN ENGINE AND CHASSIS VALUE FEATURES

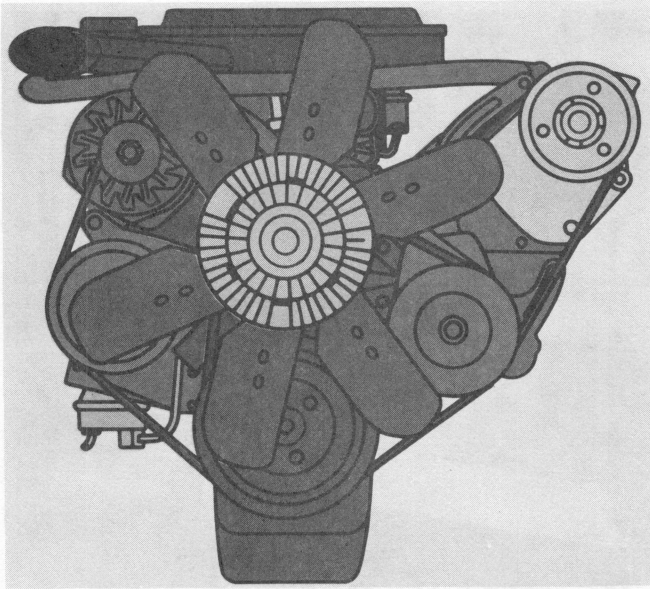

## Three V8s

- The 305 V8 with a 2-barrel carburetor is available V8 on G10 models, except 125-inch wheelbase Sportvan. Good performance, efficient operation on unleaded fuel. Not available in California; the 350-4 V8 is required.
- 350 V8 with 4-barrel carburetor is available V8 on 125-inch wheelbase G10 Sportvan, G20 and G30 models. Available on other G10 models.
- 400 V8 available on G20 and G30 models.

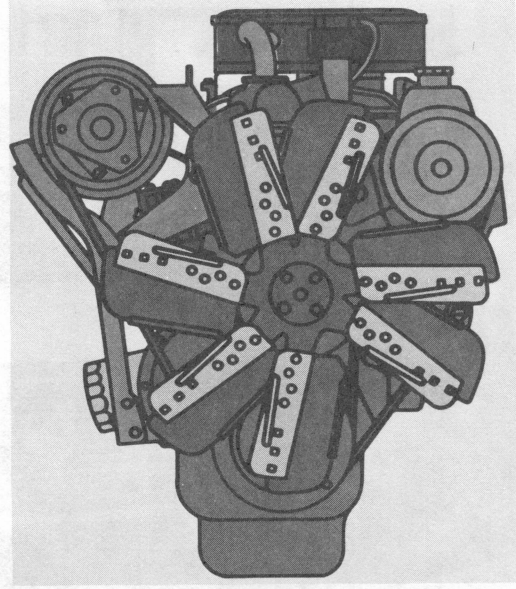

## Two Sixes

- Integral head-inlet manifold 250 Six standard on G10 models.
- High-torque 292 Six standard on G20 and G30 models.
- High Energy Ignition system standard equipment on all engines. Helps provide quick starting.
- Recommended service intervals help save on maintenance costs: oil change, 7,500 miles; oil filter, 15,000 miles; chassis lube, 7,500 miles; spark plug change, 22,500 miles for V8s and 30,000 miles for L6s; automatic transmission service, 60,000 miles now.

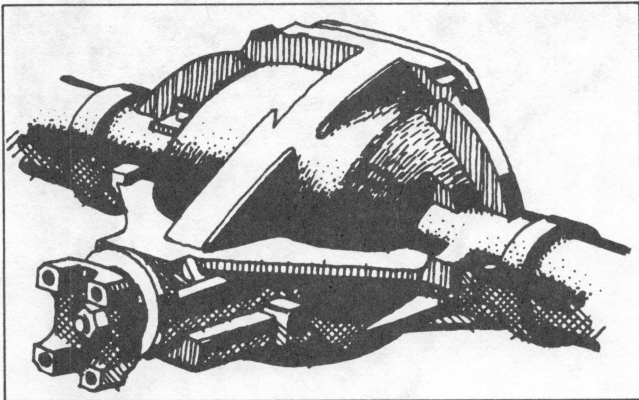

## Rear Axles

- 5700-lb. capacity Salisbury full-floating design for G30 models offers durability under heavy loads plus broad ratio coverage.
- Semi-floating design on G10-20 models.

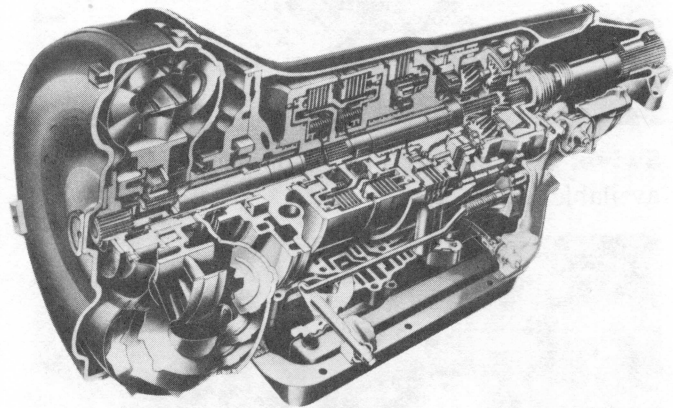

## Transmissions

- 3-speed synchromesh transmission standard.
- Fully automatic Turbo Hydra-matic is available with all engines.



# 1977 CHEVY VAN/SPORTVAN CHASSIS VALUE FEATURES

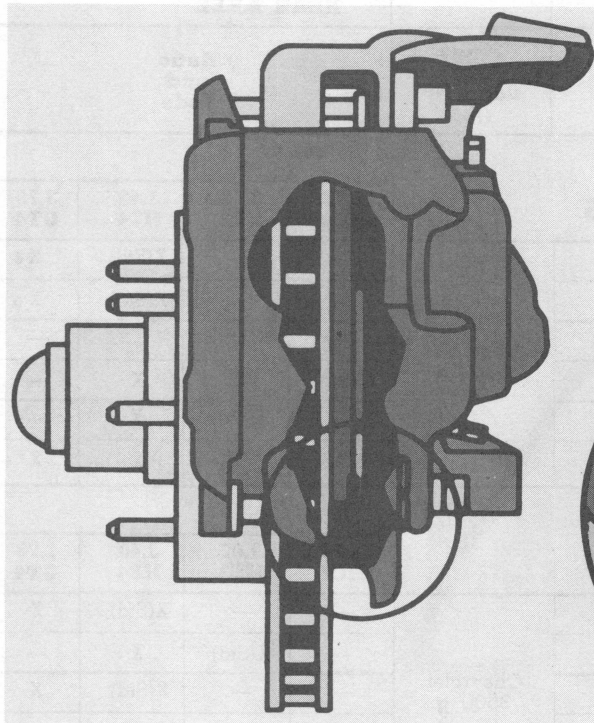

## Computer-Matched Braking Systems

- Brake size and capacity computer-selected by GVW rating.

## Front Pad Wear Sensor

- Rubs rotor when pad is worn.
- Audible signal indicates need for maintenance.

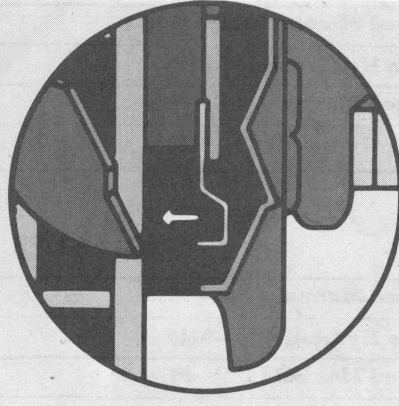

## Two-Stage Multi-Leaf Rear Springs

- Automatically adjust to the load.
- Spring design features an eight-leaf assembly for the higher GVW ratings.

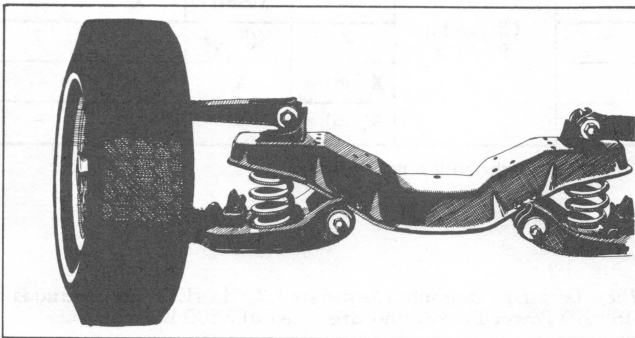

## Massive Girder Beam Independent Front Suspension

- Helps iron out the road for a smoother ride.
- Control arms on Series 10 and 20 models feature rubber bushings to reduce road harshness.
- A tough coil spring at each wheel helps soak up road shock.

## Wide-Stance Chassis Design

- Good stability and responsiveness.

## Aluminized Exhaust System

- Coated inside and out.
- Hangers allow heat expansion.

## Counter-Angled Rear Shocks

- Effect is to reduce wheel hop.
- New heavy-duty 32mm shocks are available.

## Prelubricated Universal Joints

- Reduce maintenance.

## Integral Body and Frame

- Permanently joined for strength and durability.
- Critical underbody components galvanized for corrosion protection.

## Front Stabilizer Bar Available

- For stability and driving ease.
- Recommended for highway use.
- Required for high center of gravity loads.

# 1977 CHEVY VAN POWER TEAMS

ENGINE	TRANSMISSION		REAR AXLE
Type and Code	Type and Code	Make and Capacity (lb)	Ratio and Code

## G10 SERIES

			2.73 HC2	3.08 HE3	3.42 HE4	3.73 GT4
■ 250 1-bbl L6—LD4 (Standard Engine)	3-Speed Manual (Std)—M15 a	Chevrolet 3100 b	—	—	X(Std)	X♦
	Turbo Hydra-matic—M40		—	—	X(Std)	X♦
●▲ 305 2-bbl V8—LG9	3-Speed Manual (Std)—M15		—	X(Std)	X	—
	Turbo Hydra-matic—M40		X(Std)	X	X	—
■ 350 4-bbl V8—LS9	3-Speed Manual (Std)—M15 ▲		—	X(Std)	X	—
	Turbo Hydra-matic—M40 ♦		X(Std)	X	X	X*♦

## G20 SERIES

			2.76 HC2	3.07 HE3	3.40 HE4	3.73 GT4
■ 292 1-bbl L6—L25 (Standard Engine)	3-Speed Manual (Std)—M15	Chevrolet 3500 g	—	—	X(Std)	X
	Turbo Hydra-matic—M40		—	X(Std)	X	—
■ 350 4-bbl V8—LS9	3-Speed Manual (Std)—M15		—	—	X(Std)	X
	Turbo Hydra-matic—M40		X(Std)	—	X	—
■ 400 4-bbl V8—LF4	Turbo Hydra-matic—M40		X(Std)	—	X	—

## G30 SERIES

			3.21 HC8	3.73 GT4	4.10 GT5	4.56 HC4
■ 292 1-bbl L6—L25 (Standard Engine)	3-Speed Manual (Std)—M15 d	Chevrolet 5700 c	—	—	X(Std)	X
	Turbo Hydra-matic—M40		—	X(Std)	X	—
■ 350 4-bbl V8—LS9	3-Speed Manual (Std)—M15		—	X(Std)f	X	X
	Turbo Hydra-matic—M40		X(Std) e	X	X	—
■ 400 4-bbl V8—LF4	Turbo Hydra-matic—M40		X(Std) e	X	X	—

■ Available for registration in the State of California when California Emission Certification is ordered.

● Not available for registration in the State of California.

▲ Not available with NA6 High Altitude Emission Equipment.

♦ Required when NA6 High Altitude Emission Equipment is ordered.

\* Available only when NA6 High Altitude Emission Equipment is ordered.

a Not recommended for GVWR of 5400 lb. or above.

b Locking Differential available only on Code HC2 and HE3 axles. When Locking Differential is ordered, Code HC2 axle changes to 2.76 ratio, and Code HE3 changes to 3.07 ratio. Both axles require J55 HD Power Brakes and are rated at 3500 lbs. capacity.

c Locking Differential available on all axles; HC4 requires J55 Brakes.

d Not recommended for GVWR of 7700 lb. or above.

e 7700 lb. GVWR or above requires GT4 or GT5 axle ratio (not recommended for normal passenger use.)

f Not recommended for GVWR of 7900 lb. or above.

g Locking Differential available only on Code HC2 and HE4 axles.

## ENGINE RATINGS

SAE Net Ratings @ 85°F	250 1-bbl L6*	292 1-bbl L6	305 2-bbl V8*	350 4-bbl V8*	400 4-bbl V8
Net Horsepower . . . . .	110 @ 3800 rpm	120 @ 3600 rpm	145 @ 3800 rpm	165 @ 3800 rpm	175 @ 3600 rpm
Net Torque, lb-ft. . . . .	195 @ 1600 rpm	215 @ 2000 rpm	245 @ 2400 rpm	†260 @ 2400 rpm	290 @ 2800 rpm

\*Light Duty Emissions. †Rated 255 @ 2800 rpm for Heavy Duty Emissions.



# 1977 SPORTVAN POWER TEAMS

ENGINE	TRANSMISSION		REAR AXLE
Type and Code	Type and Code	Make and Capacity (lb)	Ratio and Code

## G10 SERIES

			2.73 HC2	3.08 HE3	3.42 HE4	3.73 GT4
■ 250 1-bbl L6—LD4 (Standard Engine)	3-Speed Manual (Std)—M15 a	Chevrolet 3100 g	—	—	X(Std)	X♦
	Turbo Hydra-matic—M40		—	—	X(Std)	X♦
●*▲ 305 2-bbl V8—LG9	3-Speed Manual (Std)—M15		—	X(Std)	X	—
	Turbo Hydra-matic—M40		X(Std)	X	X	—
■ 350 4-bbl V8—LS9	3-Speed Manual (Std)—M15▲		—	X(Std)	X	—
	Turbo Hydra-matic—M40♦		X(Std)	X	X	Xc♦

## G20 SERIES

			2.76 HC2	3.07 HE3	3.40 HE4	3.73 GT4
■ 292 1-bbl L6—L25 (Standard Engine)	3-Speed Manual (Std)—M15	Chevrolet 3500 b	—	—	X(Std)	X
	Turbo Hydra-matic—M40		—	X(Std)	X	—
■ 350 4-bbl V8—LS9	3-Speed Manual (Std)—M15		—	—	X(Std)	X
	Turbo Hydra-matic—M40		X(Std)	—	X	—
■ 400 4-bbl V8—LF4	Turbo Hydra-matic—M40		X(Std)	—	X	—

## G30 SERIES

			3.21 HC8	3.73 GT4	4.10 GT5
■ 292 1-bbl L6—L25 (Standard Engine)	3-Speed Manual (Std)—M15 d	Chevrolet 5700 e	—	—	X(Std)
	Turbo Hydra-matic—M40		—	X(Std)	X
■ 350 4-bbl V8—LS9	3-Speed Manual (Std)—M15		—	X(Std)h	X
	Turbo Hydra-matic—M40		X(Std) f	X	X
■ 400 4-bbl V8—LF4	Turbo Hydra-matic—M40		X(Std) f	X	X

■ Available for registration in the State of California when California Emission Certification is ordered.

● Not available for registration in the State of California.

\* Not available on 125" WB models.

▲ Not available with NA6 High Altitude Emission Equipment.

♦ Required when NA6 High Altitude Emission Equipment is ordered.

a Not recommended for GVWR of 5400 lb. or above.

b Locking Differential available only on Code HC2 and HE3 axles. When Locking Differential is ordered, Code HC2 axle changes to 2.76 ratio, and Code HE3 changes to 3.07 ratio. Both axles are rated at 3500 lb. capacity.

c Available only when NA6 High Altitude Emission Equipment is ordered.

d Not recommended for GVWR of 7100 lb. or above.

e Locking Differential available for all axles.

f 7900 lb GVWR or above requires GT4 or GT5 axle ratio (not recommended for normal passenger use).

g Locking Differential available only on Code HC2 and HE4 axles.

h Not recommended for GVWR of 7900 lb. or above.

## ENGINE RATINGS

SAE Net Ratings @ 85°F	250 1-bbl L6*	292 1-bbl L6	305 2-bbl V8*	350 4-bbl V8*	400 4-bbl V8
Net Horsepower .....	110 @ 3800 rpm	120 @ 3600 rpm	145 @ 3800 rpm	165 @ 3800 rpm	175 @ 3600 rpm
Net Torque, lb-ft .....	195 @ 1600 rpm	215 @ 2000 rpm	245 @ 2400 rpm	†260 @ 2400 rpm	290 @ 2800 rpm

\*Light Duty Emissions.

†Rated 255 @ 2800 rpm for Heavy Duty Emissions.

# 1977 CHEVY VAN/SPORTVAN POPULAR OPTIONS

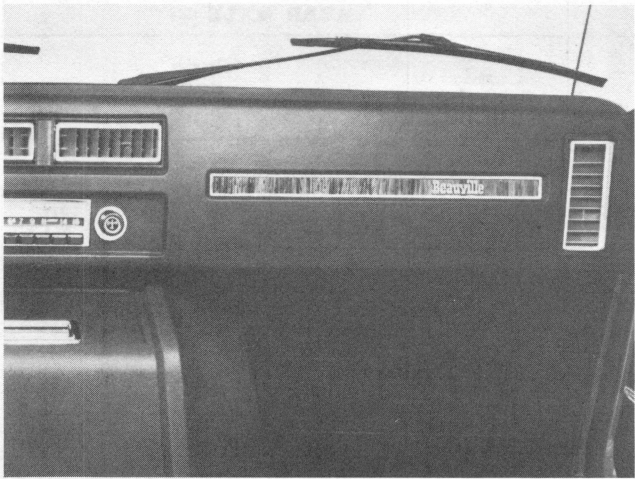

**All Weather air conditioning** • Cools and dehumidifies incoming air • Basic package is a front-mounted unit • Additional rear overhead recirculating unit with separate control switch also available with front unit.

**Comfortilt steering wheel** • Adjusts to six different positions for almost anybody's driving comfort • Available on all models with automatic transmission.

**15" Rally wheels** • Available on Series G10-20. Chevy Van and Sportvan models • Includes wheel, center hub, bright trim ring.

**33-gallon fuel tank** • Available on 125" wheelbase models only • Replaces standard 21-gallon tank • Increases cruising range.

**New roof vent** • White, translucent plastic • Standard on Caravan • Available on Chevy Van, Sportvan and Nomad.

**New rear step bumper** • Available for Chevy Van, Sportvan • Skid-resistant surface, painted finish • Pre-drilled for trailer-hitch ball, available in 1 7/8" and 2" sizes.

**New wheels** • White, styled-steel wheels.

**High-back bucket seats** • Attractive comfortable high-back bucket seats are available with standard all-vinyl trim • With special all-vinyl or plaid cloth and vinyl trims, they're standard on the Beauville Sportvan, Nomad and Chevy Van with Beauville trim.

**New swivel bucket seats** • Available in custom cloth or custom vinyl depending on model. Check chart on page 17 for availability.

**Turbo Hydra-matic** • Available on all models • Delivers responsive performance • Three speeds forward • Steering-column-mounted selector lever.

**Steel-belted radial ply whitewall tires** • Available in GR78-15B, JR78-15B sizes • Features include durability, traction and impact resistance.

**Eaton locking differential** • Available on all models • Unit operates at about 100-rpm differential in speed between two rear wheels • Deactivated at high speeds • Helps eliminate chatter, shock, excessive tire wear.

## Other Popular Options:

- New swing-out side door glass. Chevy Van only.
- AM-FM radio.
- New rear-mounted speaker. Custom and Beauville Sportvan, Nomad and Caravan only.
- AM radio.
- Custom steering wheel.
- Power steering.
- Passenger seat adjuster.
- Chromed grille (included on Beauville Sportvan, Nomad and with Custom Appearance Equipment).
- Heavy-duty Delco Freedom battery.
- Chromed bumpers.
- New painted or chromed front bumper guards (125" wheelbase models only).
- Heavy-duty cooling.
- Heavy-duty radiator.
- Custom Appearance Equipment.
- Custom Comfort Equipment.
- Gauges—voltmeter, temperature, oil pressure.
- 42-amp generator.
- 61-amp generator.
- Swing-out rear door glass.
- Rear heater.
- Below Eyeline mirrors.
- Cigar lighter.
- Body side moldings.
- Special two-tone paint.
- Deluxe two-tone paint.
- Heavy-duty shock absorbers.
- Heavy-duty springs.
- Front stabilizer bar.
- Bright metal hubcaps.
- Bright metal trim rings (require P03).



# 1977 CHEVY VAN SPECIAL OPTIONS

## General Service

Typical factory-installed general service package includes: bin with open back, utility cabinet with shelves and dividers, bin with shelf, adjustable shelf unit, drawer units, utility cabinet and security screen.

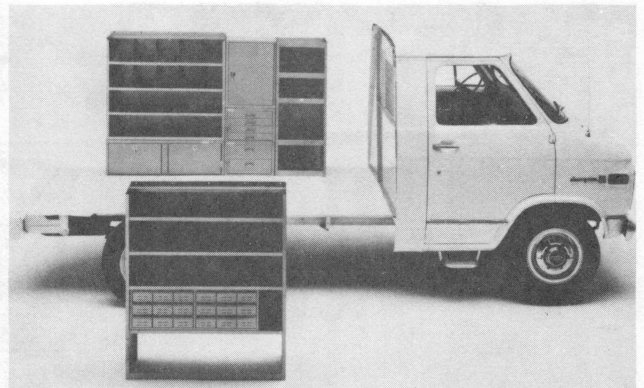

## Electric and Gas Appliance Service

Package includes: stool, bins with open back, workbench, 9-drawer units, adjustable shelf rack, cabinet with adjustable shelf, medium drawer units, bins with door and shelf, catalog file, welded shelf rack and security screen.

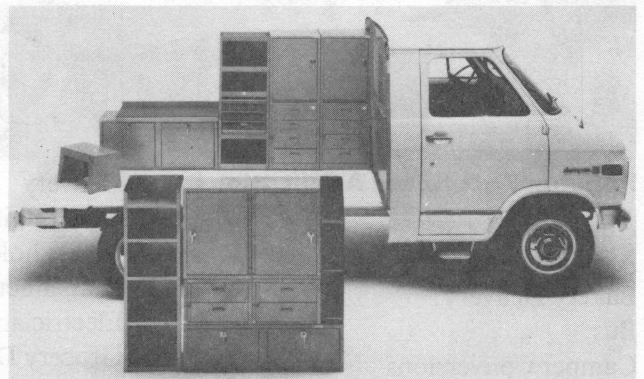

## Plumbing, Heating and Air-Conditioning Service

This installation includes: catalog file, utility cabinets with shelves and dividers, utility cabinet with shelves and drawers, welded shelf unit, bin with open back, medium drawer units, adjustable shelf unit, 9-drawer unit and security screen.

Refer to your 1977 Chevrolet Truck Data Book Special Equipment Section for additional factory-installed equipment for Chevy Vans.

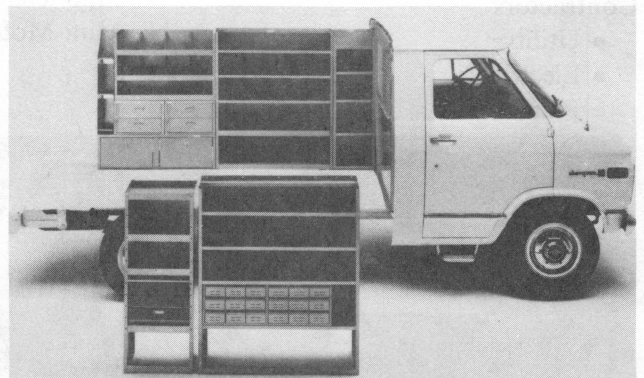

# 1977 CHEVY VAN VOCATIONAL APPLICATIONS



## Popular Vocational Applications

Ambulance  
Appliance Installers  
Bakery Delivery  
Bus  
Camper Conversions  
Caterers  
Cleaners  
Contractors  
• Utility  
• Electrical  
• Plumbing

Delivery  
• Retail  
• Wholesale  
Diaper Service  
Electricians  
Grocery Delivery  
Laundry Delivery  
Linen Supply  
Maintenance  
Mini-Motor Home Conversions

Painters and Decorators  
Parcel Delivery  
Plumbers  
Public Utility  
Rescue Truck  
Service Utility  
Trailer Towing  
TV Mobile Service Units  
Vending Service

## Recreational Applications





# 1977 CHEVY VAN/SPORTVAN INTERIOR VALUE FEATURES

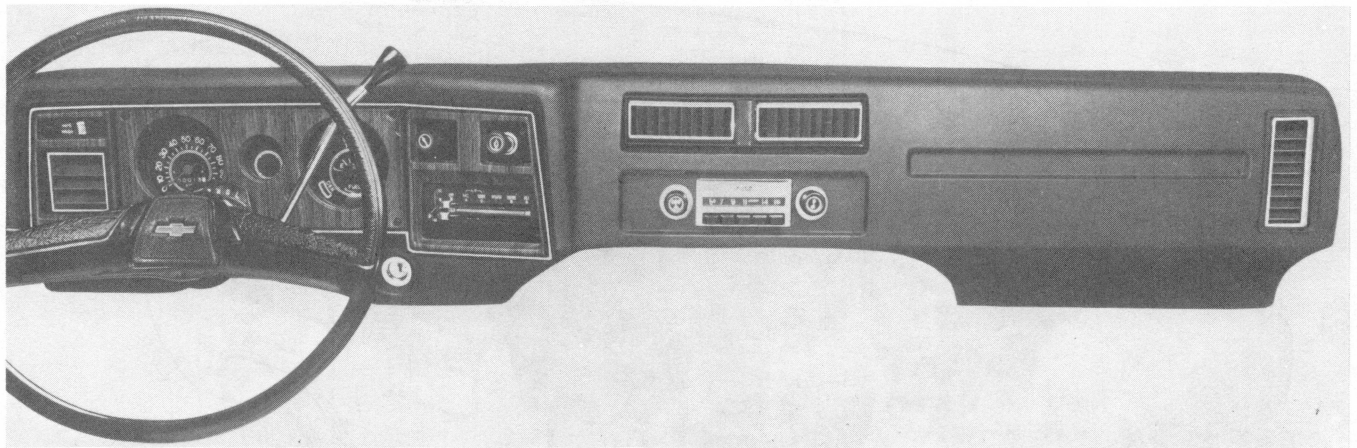

## Attractive, Efficient Instrument Panel

- Functional design, attractive styling.
- Incorporates all front air-conditioning outlets for efficient distribution of cool air.
- Front air-conditioning evaporator-blower located on dash for unobstructed access to rear compartment.
- Cockpit type instrument cluster.
- Controls placed conveniently for driver.
- All control functions identified.

## Forward Engine Location

- Gives 142 inches —nearly 12 feet —of clear load space between rear doors and back of engine (125" WB).
- Maximum load length of almost 14 feet (125" WB).
- Double-wall construction of engine housing, with added insulation in between, helps keep out sound and heat.

## Seating for Up to 12

- Seating for 5 in Nomad.
- On Series 20 and 30 Sportvans, a second rear bench seat can be ordered to carry 8.
- On Series 30 Sportvans, a full-width third rear seat is available to raise seating capacity to 12.

## Quick-Release Feature

- All Sportvan and Nomad bench seats are secured to the floor by cam-type front latches and hooked rear retainers that fit onto anchor pins. When latches are released, the seat can be slid off rear anchors, lifted and removed. Sportvan and Nomad convert from people- to cargo-carrying fast!

## Beauville Interior:

- Standard high-back front bucket seats and conventional rear bench seat available in choice of Green or Mandarin Orange all-vinyl trim or Blue, Buckskin or Red cloth-and-vinyl trim. Cloth is luxurious plaid nylon.
- Soft vinyl door and sidewall trim panels, color-coordinated to seat trim colors, with simulated wood-grain trim, door-closing assist strap for sliding side door and stowage pockets on front doors.
- Two-piece vinyl and foam headliner insulator.

## Standard Sportvan Interior:

- Comes with two low-back front bucket seats and a full-width rear bench seat —all foam padded.
- Attractive grained vinyl upholstery in Blue, Green, Buckskin or Mandarin Orange. High-back front bucket seats with standard trim available.

## Standard Chevy Van Interior:

- Comes with foam-padded driver's bucket seat; matching passenger seat available. Embossed plaid vinyl upholstery: Blue, Green, Buckskin or Mandarin Orange.
- New Beauville trim for Chevy Van front driver and passenger area available.

# 1977 CHEVY SPORTVAN AND NOMAD SEATING ARRANGEMENTS FOR STANDARD AND OPTIONAL SEATS

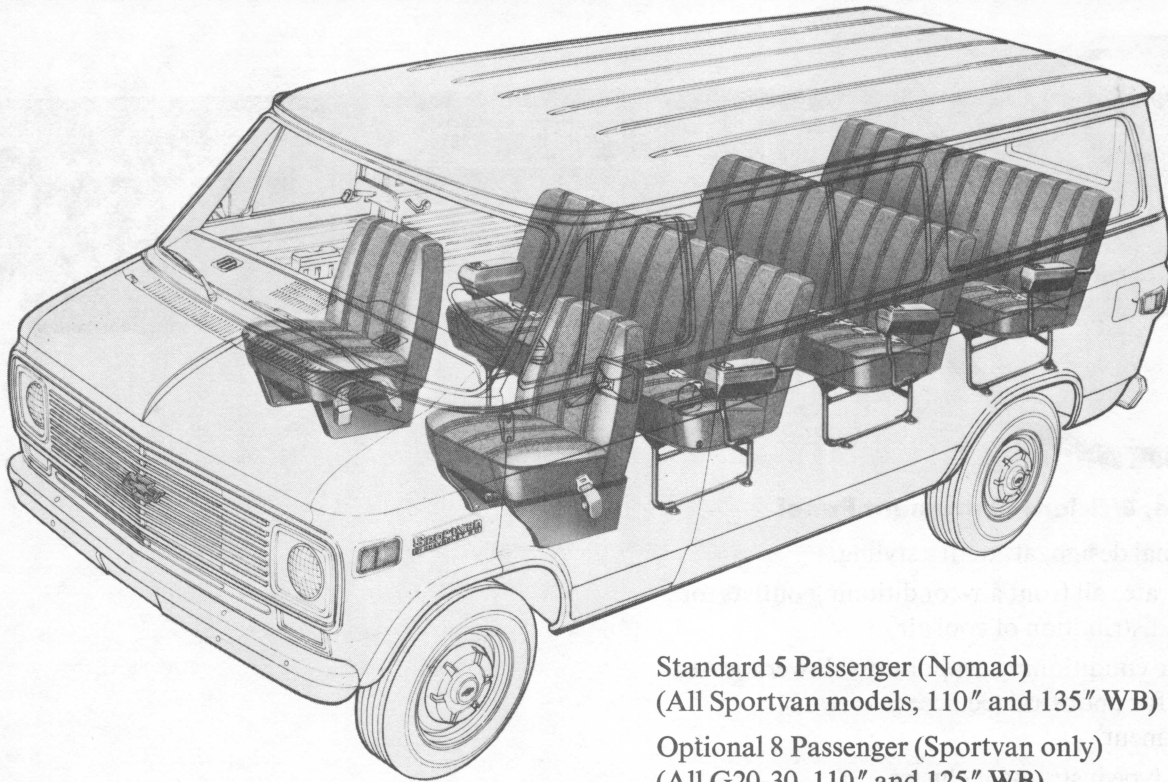

Standard 5 Passenger (Nomad)  
(All Sportvan models, 110" and 135" WB)

Optional 8 Passenger (Sportvan only)  
(All G20-30, 110" and 125" WB)

Optional 12 Passenger (Series 30 only, on 125" WB)  
(Sportvan only)

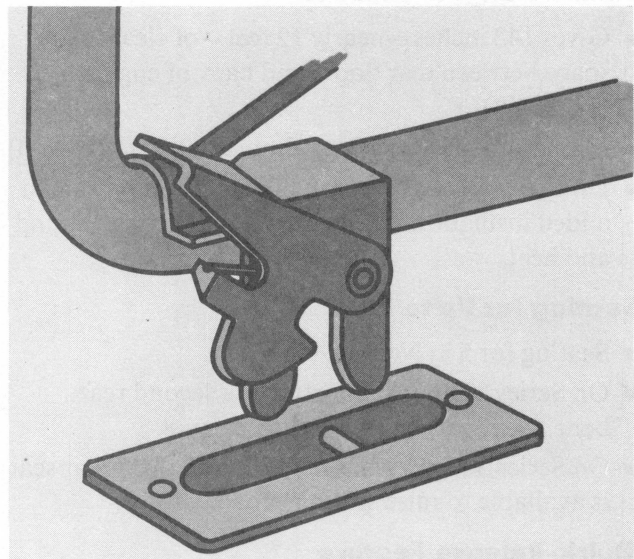
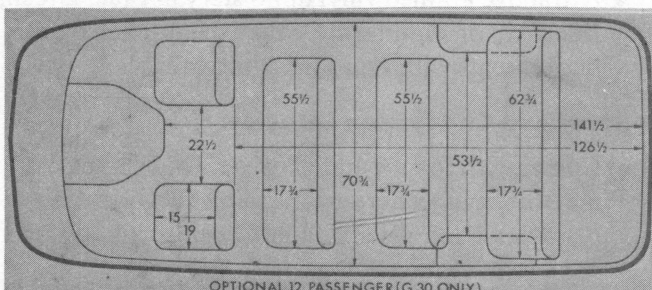
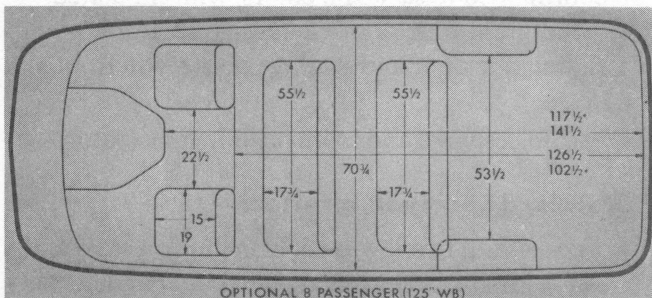
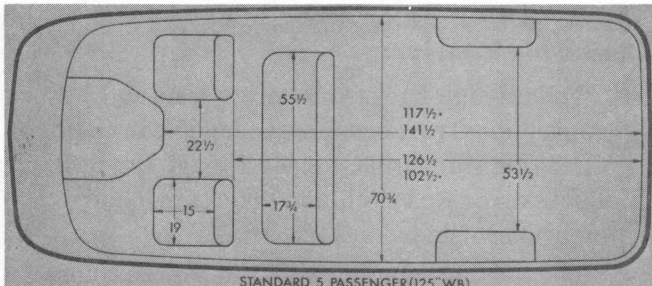

## Quick-release bench seats

- Cam-type front latches help convert Sportvan and Nomad from people- to cargo-carrying in a hurry.
- When latches are released, seats can be slid off rear anchor pins, lifted and removed—just about as quick as that.
- To reinstall, simply reverse the procedure.



# 1977 CHEVY VAN EXTERIOR COLORS AND INTERIOR TRIMS

Please Note: Exterior and interior combinations shown in charts below are those recommended by Chevrolet; however, any exterior color combination may be ordered with any available interior color if the particular combination is desired by a customer.

SEAT TRIM			MODEL OPTION				SEAT TRIM COLOR AND ORDERING CODE				
Fabric	▲Code	Bucket Seat Type	Standard or Custom Z62	Caravan ZM1	Nomad ZM4	Beauville ZM8	Blue	Green	Buckskin	Mandarin Orange	Red
Standard Vinyl	V	Low Back	X				VDD2	VGG2	VUU2		VRR2
		High Back	X				VDD4	VGG4	VUU4		VRR4
Custom Vinyl	W	High Back			X	X		XGG4		XMM4	
		Swivel	X	X		X			XUU6		
Custom Cloth	G	High Back			X	X	CDD4		CUU4		CRR4
		Swivel	X	X	X	X	CDD6		CUU6		CRR6
♦ EXTERIOR COLORS			Primary	Secondary	RECOMMENDED INTERIOR TRIM COLORS						
<b>BLACK, MIDNIGHT</b>			86	86	X	X	X	X	X	X	X
Buckskin			86	65				X	X		
Mahogany			86	76					X		X
Tan, Santa Fe			86	60	X			X	X		X
White, Frost			86	12	X	X		X	X		X
<b>BLUE, LITE (Light)</b>			20	20	X						
White, Frost			20	12	X						
<b>BLUE, HAWAIIAN (Medium)</b>			23	23	X						
Blue, Lite			23	20	X						
White, Frost			23	12	X						
<b>BLUE, REDONDO (Dark) (M)</b>			84	84	X			X			
Blue, Lite			84	20	X			X			
White, Frost			84	12	X			X			
<b>BROWN, CORDOVA (Dark) (M)</b>			81	81				X	X		
Buckskin			81	65				X	X		
Tan, Santa Fe			81	60				X	X		
White, Frost			81	12				X	X		
<b>BUCKSKIN</b>			65	65				X	X		X
Mahogany			65	76				X			X
Tan, Santa Fe			65	60				X	X		X
White, Frost			65	12				X	X		X
<b>GREEN, SEAMIST (Light) (M)</b>			43	43			X	X			
Green, Holly			43	46			X	X			
White, Frost			43	12			X	X			
<b>GREEN, HOLLY (Dark)</b>			46	46			X	X			
Buckskin			46	65			X	X			
Tan, Santa Fe			46	60			X	X			
White, Frost			46	12			X	X			
<b>MAHOGANY</b>			76	76				X			X
Tan, Santa Fe			76	60				X			X
White, Frost			76	12				X			X
<b>RED, CARDINAL (Medium)</b>			70	70				X			X
Mahogany			70	76				X			X
Tan, Santa Fe			70	60				X			X
White, Frost			70	12				X			X
<b>RED, METALLIC (Dark) (M)</b>			71	71				X			X
Buckskin			71	65				X			X
Mahogany			71	76				X			X
Tan, Santa Fe			71	60				X			X
White, Frost			71	12				X			X
<b>SILVER, SARATOGA (M)</b>			17	17		X	X				X
Green, Holly			17	46			X				
Mahogany			17	76					X		X
White, Frost			17	12		X	X				X
<b>TAN, SANTA FE</b>			60	60			X	X	X	X	X
Buckskin			60	65			X	X	X		X
Green, Holly			60	46			X	X			
Mahogany			60	76				X			X
White, Frost			60	12				X	X	X	X
<b>WHITE, FROST</b>			12	12		X	X	X	X		X
Blue, Lite			12	20		X		X			
Buckskin			12	65		X		X	X		
Green, Holly			12	46		X	X	X			
Mahogany			12	76				X			X
<b>YELLOW, COLONIAL</b>			53	53				X			
Tan, Santa Fe			53	60				X			
White, Frost			53	12				X			

♦ Primary color shown in **BOLDFACE TYPE**; secondary colors shown in Lightface Type. (M): Metallic.

▲ Seat Trim Codes: V—Plaid Pattern Vinyl; W—Buffalo Hide Vinyl; G—Plaid Pattern Cloth

# 1977 SPORTVAN EXTERIOR COLORS AND INTERIOR TRIMS

Please Note: Exterior and interior combinations shown in charts below are those recommended by Chevrolet; however, any exterior color combination may be ordered with any available interior color if the particular combination is desired by a customer.

SEAT TRIM			MODEL OPTION		SEAT TRIM COLOR AND ORDERING CODE				
Fabric	▲Code	Bucket Seat Type	Standard or Custom Z62	Beauville E94	Blue	Green	Buckskin	Mandarin Orange	Red
Standard Vinyl	V	Low Back	X		VDD2	VGG2	VUU2		VRR2
		High Back	X		VDD4	VGG4	VUU4		VRR4
Custom Vinyl	W	High Back		X		XGG4		XMM4	
		High Back		X	CDD4		CUU4		CRR4
Custom Cloth	G	Swivel		X	CDD6		CUU6		CRR6
♦ EXTERIOR COLORS			Primary	Secondary	RECOMMENDED INTERIOR TRIM COLORS				
<b>BLACK, MIDNIGHT</b>			86	86	X	X	X	X	X
Buckskin			86	65			X	X	
Mahogany			86	76			X		X
Tan, Santa Fe			86	60	X		X	X	X
White, Frost			86	12	X	X	X	X	X
<b>BLUE, LITE (Light)</b>			20	20	X				
White, Frost			20	12	X				
<b>BLUE, HAWAIIAN (Medium)</b>			23	23	X				
Blue, Lite			23	20	X				
White, Frost			23	12	X				
<b>BLUE, REDONDO (Dark) (M)</b>			84	84	X		X		
Blue, Lite			84	20	X		X		
White, Frost			84	12	X		X		
<b>BROWN, CORDOVA (Dark) (M)</b>			81	81			X	X	
Buckskin			81	65			X	X	
Tan, Santa Fe			81	60			X	X	
White, Frost			81	12			X	X	
<b>BUCKSKIN</b>			65	65			X	X	X
Mahogany			65	76			X		X
Tan, Santa Fe			65	60			X	X	X
White, Frost			65	12			X	X	X
<b>GREEN, SEAMIST (Light) (M)</b>			43	43		X	X		
Green, Holly			43	46		X	X		
White, Frost			43	12		X	X		
<b>GREEN, HOLLY (Dark)</b>			46	46		X	X		
Buckskin			46	65		X	X		
Tan, Santa Fe			46	60		X	X		
White, Frost			46	12		X	X		
<b>MAHOGANY</b>			76	76			X		X
Tan, Santa Fe			76	60			X		X
White, Frost			76	12			X		X
<b>RED, CARDINAL (Medium)</b>			70	70			X		X
Mahogany			70	76			X		X
Tan, Santa Fe			70	60			X		X
White, Frost			70	12			X		X
<b>RED, METALLIC (Dark) (M)</b>			71	71			X		X
Buckskin			71	65			X		X
Mahogany			71	76			X		X
Tan, Santa Fe			71	60			X		X
White, Frost			71	12			X		X
<b>SILVER, SARATOGA (M)</b>			17	17	X	X			X
Green, Holly			17	46		X			
Mahogany			17	76			X		X
White, Frost			17	12	X	X			X
<b>TAN, SANTA FE</b>			60	60		X	X	X	X
Buckskin			60	65		X	X	X	X
Green, Holly			60	46		X	X		
Mahogany			60	76			X		X
White, Frost			60	12		X	X	X	X
<b>WHITE, FROST</b>			12	12	X	X	X	X	X
Blue, Lite			12	20	X		X		
Buckskin			12	65	X		X	X	
Green, Holly			12	46	X	X	X		
Mahogany			12	76			X		X
<b>YELLOW, COLONIAL</b>			53	53			X		
Tan, Santa Fe			53	60			X		
White, Frost			53	12			X		

♦ Primary color shown in **BOLDFACE TYPE**; secondary colors shown in Lightface Type. (M): Metallic.

▲ Seat Trim Codes: V—Plaid Pattern Vinyl; W—Buffalo Hide Vinyl; G—Plaid Pattern Cloth



# 1977 CHEVY VAN/SPORTVAN VALUE FEATURES

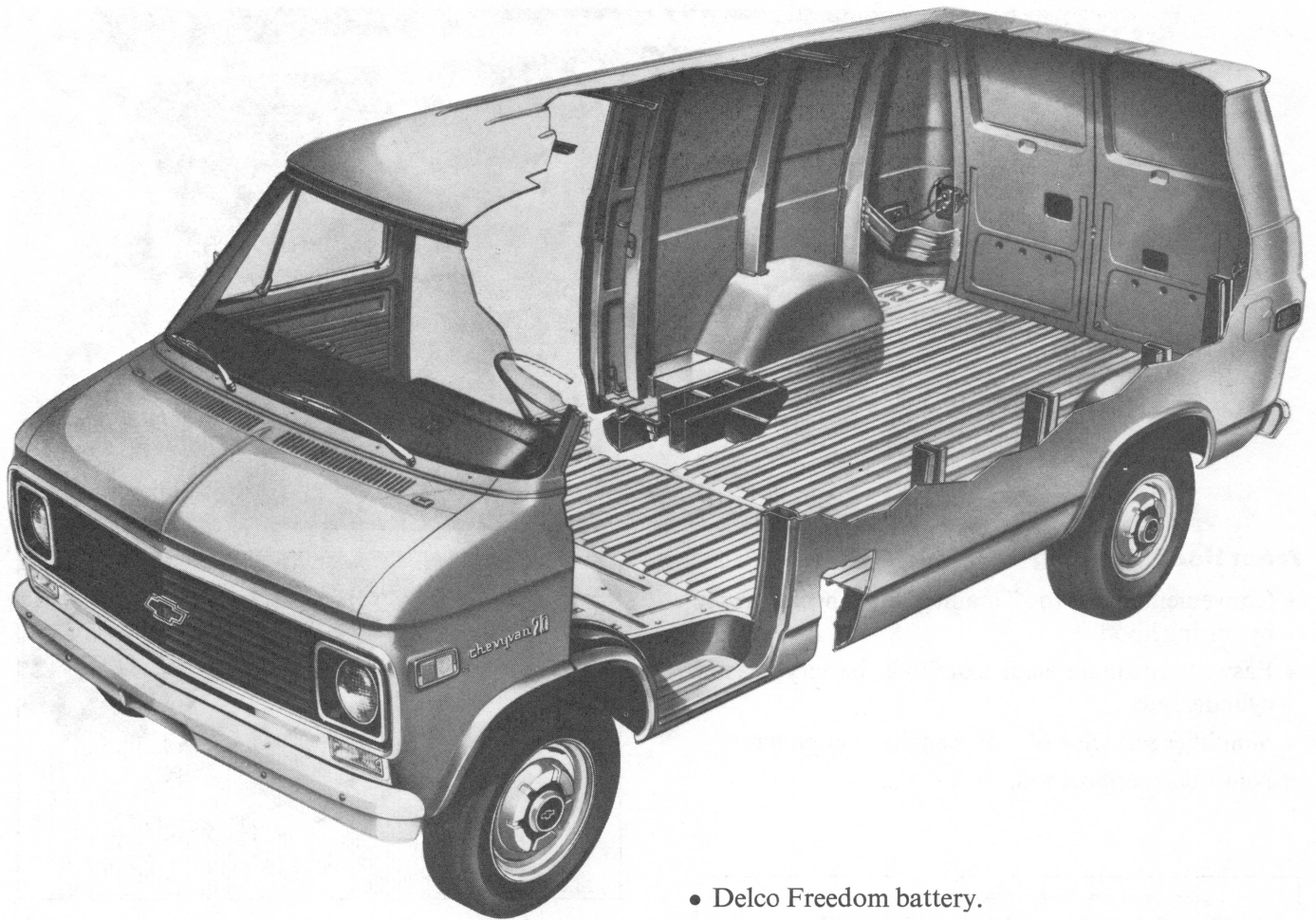

## Value Comes Standard, Inside and Out

- Contemporary styling for good looks and utility.
- Forward engine location for added cargo space.
- Front-opening hood for improved accessibility.
- Front engine service — 27 maintenance items accessible.
- High-level air intake for heating /ventilation system.
- Instruments and controls grouped for driver convenience.
- Speedometer indicates kilometers per hour as well as miles per hour.
- Interior decor styled for good looks.
- Foot-operated parking brake for driver convenience.
- Right side sliding side door for easy loading — requires only 4½ inches of clearance.
- Concealed front and side door steps for easy access to cargo or seating area.
- Delco Freedom battery.
- Wide rear door opening, a full 54.4 inches — opens a full 180° for easy dock loading.
- Spacious cargo area.
  - Up to 296 cu. ft. of load space (Chevy Van).
  - Almost 14 ft. maximum load length (Chevy Van).
- Engine housing cover has ashtray, handy storage bin and added heat insulation.
- Large glass area for good visibility.
- Total of 4 color-keyed interior trims.
- Fifteen paint colors.
- Body and doors ELPO-primed to fight rust.
- Aluminum-coated exhaust system for added life.
- Wide tread for stability, improved handling.
- Fully independent coil-spring front suspension.
  - Minimizes road shock.
  - Helps protect cargo.
  - Smooths ride.
- Two-stage multi-leaf rear springs.
  - Easy ride when empty.
  - Firm support fully loaded.

# 1977 CHEVY VAN/SPORTVAN VALUE FEATURES

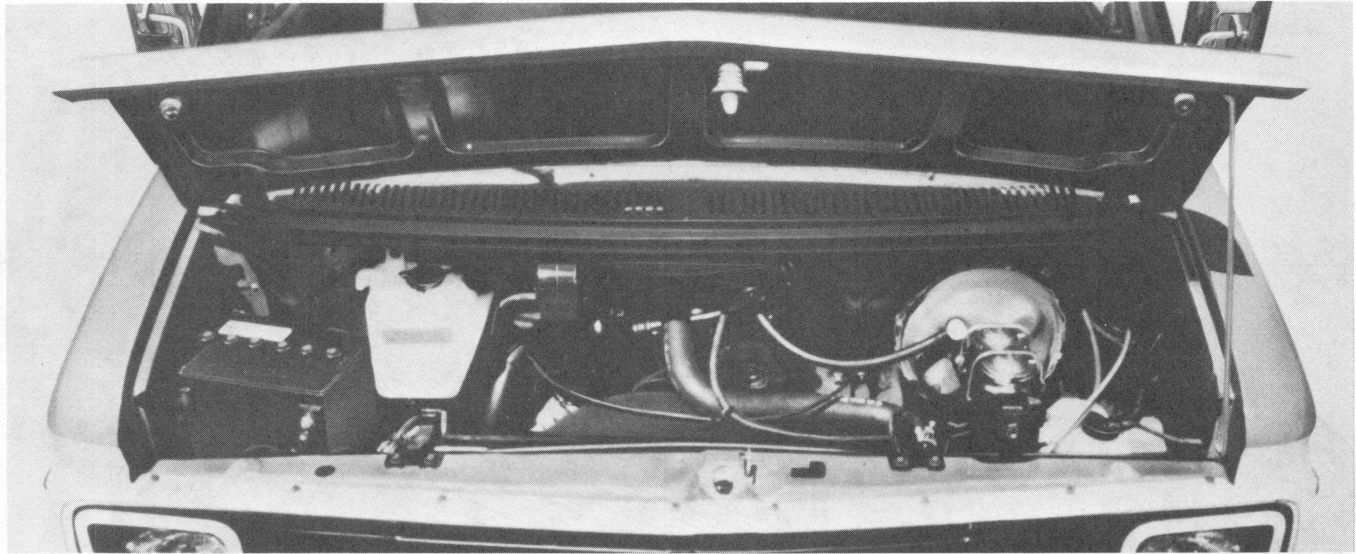

## Front Hood Opening

- Convenient access to 27 maintenance checks simply by raising hood.
- Easy routine maintenance of fluids, battery, master cylinder, etc.
- Simplifies servicing of major engine components.
- New hood support rod.

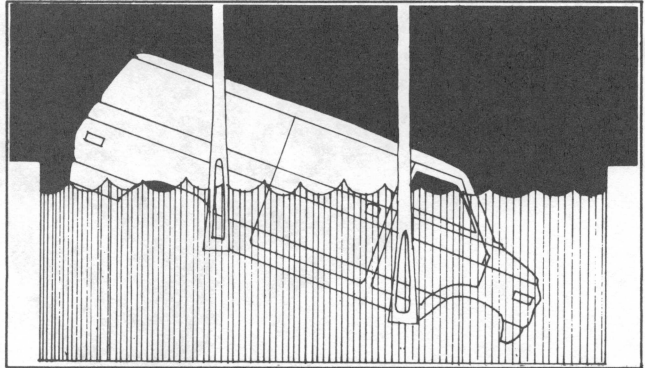

## Sliding Side Door

- Easily opened with one hand from inside or out.
- Requires only 4½ inches of clearance.
- Glides on wear-resistant steel ball bearings which do not need lubrication.
- Sliding door mechanism revised to improve latching and unlocking.

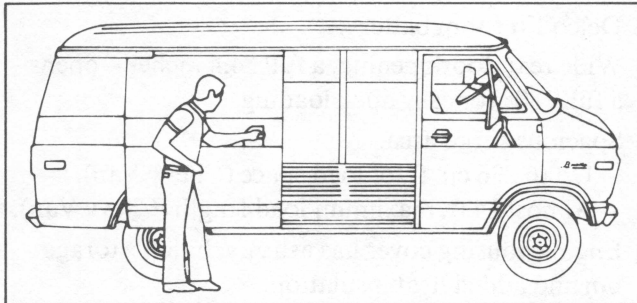

## All Bodies and Doors Electro-Coated Before Painting

- Completely immersed in primer.
- Electrically charged to draw emulsion into every corner and crevice.

## Sealers Help Keep Moisture From Critical Joints

- Wheelhousings, rocker panels and front door step panels are sprayed with underbody protective coating.
- Galvanized steel used for selected components to help combat corrosion.

## New Engine

- New 305 2-bbl V8 is standard in the G10 Chevy Van in both 110" and 125" wheelbases and G10 Sportvan with 110" wheelbase only. (350 2-bbl V8 is no longer available.)



# 1977 CHEVY VAN VALUE FEATURES

DIMENSIONS (inches)	Chevy Van 110	Chevy Van 125
	G10 G20 G30	G10 G20 G30
Wheelbase	110.0	125.0
Overall Length	177.0	201.0
Overall Width	79.5	79.5
Back of Seat to Rear Doors at Belt	95.3	118.6
Back of Seat to Rear Doors at Floor	102.5	126.5
Back of Engine Housing to Rear Doors at Floor	118.0	142.0
Maximum Cargo Length at Floor	150.6	174.7
Distance Between Wheelhousings	53.5	53.5
Maximum Inside Width at Floor	69.0	69.0
Maximum Inside Width at Belt	71.9	71.9
Maximum Inside Height	53.8	53.8
Rear Door Opening Width	54.4	54.4
Rear Door Opening Height	48.8	48.8
Side Door Opening Width	44.2	44.2
Side Door Opening Height	49.2	49.2

**Available window combinations** • Include windows in the rear doors, sliding door, on right side only or all around.

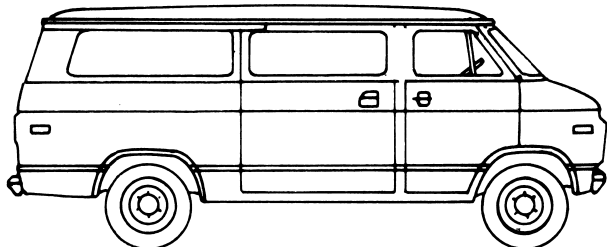

Windows all around

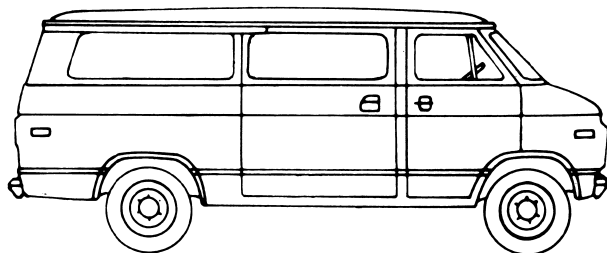

Windows on right side only

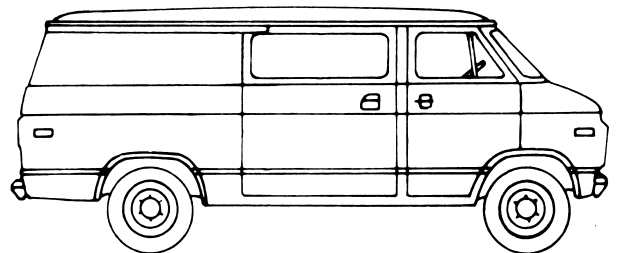

Window in sliding door (one-piece fixed or two-piece swing-out)

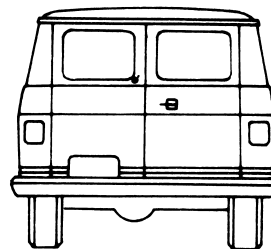

Rear Windows (stationary or swing-out)

# 1977 CHEVY VAN SPECIFICATIONS

Series	G10	G20	G30
<b>Engine</b>			
<b>Base Equip.</b> .....	250 1-bbl L6	292 1-bbl L6	292 1-bbl L6
<b>Clutch</b> .....	11", 124 sq. in.	11", 124 sq. in.	11", 124 sq. in.
<b>Air Filter</b> .....	Oiled-paper Element		
<b>Oil Filter</b> .....	Throwaway Type		
<b>Exhaust System</b> .....	Single; Aluminized		
<b>Emission Control Systems</b> .....	Meet Government Requirements		
<b>Suspension, Front</b>	Independent; Coil Springs		
<b>Capacity</b> .....	3200 lb.	3200 lb.	3900 lb.
<b>Springs @ Ground</b> .....	1310 lb. ea.	1600 lb. ea.	1700 lb. ea.
<b>Shock Absorbers</b> .....	1" dia.	1" dia.	1" dia.
<b>Suspension, Rear</b>	Salisbury Axle; Hypoid Drive; Two-stage Multi-leaf Springs		
<b>Axle Capacity</b> .....	3100 lb.	3500 lb.	5700 lb.
<b>Axle Ratio</b> .....	3.42	3.40	4.10
<b>Springs @ Ground</b> .....	1150 lb. ea.	1700 lb. ea.	2100 lb. ea.
<b>Shock Absorbers</b> .....	1" dia.	1" dia.	1" dia.
<b>Brakes</b>	Hydraulic; Self-adjusting		
<b>Front</b> .....	Disc; 11.86" Rotor	Disc; 11.86" Rotor	Disc; 12.5" Rotor
<b>Rear</b> .....	Drum; 11" x 2"	Drum; 11.15" x 2.75"	Drum; 11.15" x 2.75"
<b>Booster</b> .....	—	Dual Diaphragm	Dual Diaphragm
<b>Parking</b> .....	Cable to Rear Wheels		
<b>Electrical</b>	12 Volt; Negative Ground		
<b>Battery—Freedom Type</b> .....	2500 watts @ 0°F.	3200 watts @ 0°F.	
<b>Delcotron Generator</b> .....	37 amp.		
<b>Frame</b> .....	Integral Body-frame		
<b>Fuel Tank (nominal capacity)</b> .....	21 gal.		
<b>Steering Gear Type</b> .....	Manual; Recirculating Ball Gear		
<b>Linkage</b> .....	Parallelogram		
<b>Transmission</b> .....	Fully Synchronized 3-Speed		
<b>Shift Location</b> .....	Steering Column		
<b>Tires—110" WB</b> .....	(5)E78-15B(4PR)	(4)J78-15B(4PR)	(4)8.00-16.5C(6PR)
<b>—125" WB</b> .....	(5)F78-15B(4PR)	(4)J78-15B(4PR)	(4)8.00-16.5C(6PR)
<b>Wheels</b> .....	(5) Disc 15" x 6"	(5) Disc 15" x 6"	(5) Disc 16.5" x 6.75"



# 1977 CHEVY SPORTVAN SPECIFICATIONS

Series	G10	G20	G30
<b>Engine</b>			
<b>Base Equip.</b> .....	250 1-bbl L6	292 1-bbl L6	292 1-bbl L6
<b>Clutch</b> .....	11", 124 sq. in.	11", 124 sq. in.	11", 124 sq. in.
<b>Air Filter</b> .....	Oiled-paper Element		
<b>Oil Filter</b> .....	Throwaway Type		
<b>Exhaust System</b> .....	Single; Aluminized		
<b>Emission Control Systems</b> .....	Meet Government Requirements		
<b>Suspension, Front</b>	Independent; Coil Springs		
<b>Capacity</b> .....	3200 lb.	3200 lb.	3900 lb.
<b>Springs @ Ground</b> .....	1600 lb. ea.	1600 lb. ea.	1700 lb. ea.
<b>Shock Absorbers</b> .....	1" dia.	1" dia.	1" dia.
<b>Suspension, Rear</b>	Salisbury Axle; Hypoid Drive; Two-stage Multi-leaf Springs		
<b>Axle Capacity</b> .....	3100 lb.	3500 lb.	5700 lb.
<b>Axle Ratio</b> .....	3.42	3.40	4.10
<b>Springs @ Ground</b> .....	1600 lb. ea.	1700 lb. ea.	2100 lb. ea.
<b>Shock Absorbers</b> .....	1" dia.	1" dia.	1" dia.
<b>Brakes</b>	Hydraulic; Self-adjusting		
<b>Front</b> .....	Disc; 11.86" Rotor	Disc; 11.86" Rotor	Disc; 12.5" Rotor
<b>Rear</b> .....	Drum; 11" x 2"	Drum; 11.15" x 2.75"	Drum; 11.15" x 2.75"
<b>Booster</b> .....	Single Diaphragm	Dual Diaphragm	Dual Diaphragm
<b>Parking</b> .....	Cable to Rear Wheels		
<b>Electrical</b>	12 Volt; Negative Ground		
<b>Battery—Freedom Type</b> .....	2500 watts @ 0°F.	3200 watts @ 0°F.	
<b>Delcotron Generator</b> .....	37 amp.		
<b>Frame</b> .....	Integral Body-frame		
<b>Fuel Tank (nominal capacity)</b> .....	21 gal.		
<b>Steering Gear Type</b> .....	Manual; Recirculating Ball Gear		
<b>Linkage</b> .....	Parallelogram		
<b>Transmission</b> .....	Fully Synchronized 3-Speed		
<b>Shift Location</b> .....	Steering Column		
<b>Tires—110" WB</b> .....	(5) F78-15B (4PR)	(4) J78-15B (4PR)	—
<b>—125" WB</b> .....	(5) G78-15B (4PR)	(4) J78-15B (4PR)	(4) 8.00-16.5C (6PR)
<b>Wheels</b> .....	(5) Disc 15" x 6"	(5) Disc 15" x 6"	(5) Disc 16.5" x 6.75"

# 1977 CHEVY VAN GVWR SELECTOR

GVW Rating (lbs)	†GAWR (lbs)		Minimum Equipment Required for GVW Rating		
	Front	Rear	Tire Capacity (lbs ea)		Chassis Equipment
			Front	Rear	
<b>G10 SERIES</b>					
4800 (110" WB only)	2540	2300	1270	1270	Standard
4900 (125" WB only)	2620	2300	1370	1370	
5400	2740	2740	1370	1370	HD Front Springs (F60); HD Rear Springs (G50); Power Brakes (J50)
5600	2940	2940	1470	1470	

## G20 SERIES

6400	3200	3380	1690	1690	Standard
------	------	------	------	------	----------

†GAWR's shown are the maximum for each axle with equipment listed. Other GAWR's are available, and they are determined as the minimum capacity of either axle, springs or tires.

## FRONT AND REAR TIRE AVAILABILITY CHART

### G10 SERIES

**Spare tire to match either front or rear tires must be ordered**

FRONT			REAR			
Capacity (lbs ea)	Description	Option Number	Capacity (lbs ea)	Description	Option Number	
		Highway			Highway	On-Off Road
1270	E78-15B	<b>EV</b>	1270	E78-15B	<b>EV</b>	—
1370	F78-15B	<b>FP</b>	1370	F78-15B	<b>FP</b>	—
1370	F78-15B White Stripe	<b>FR</b>	1370	F78-15B White Stripe	<b>FR</b>	—
1370	C78-15LTC	<b>CB</b>	1370	C78-15LTC	<b>CB</b>	—
1470	G78-15B	<b>GS</b>	1470	G78-15B	<b>GS</b>	<b>GU</b>
1470	G78-15B White Stripe	<b>GT</b>	1470	G78-15B White Stripe	<b>GT</b>	—
1470	GR78-15B Radial White Stripe	<b>DR</b>	1470	GR78-15B Radial White Stripe	<b>DR</b>	—

### G20 SERIES

**Spare tire to match either front or rear tires is available at extra cost**

1690	J78-15B	<b>JC</b>	1690	J78-15B	<b>JC</b>	<b>JA</b>
1690	J78-15B White Stripe	<b>JB</b>	1690	J78-15B White Stripe	<b>JB</b>	—
1690	JR78-15B Radial White Stripe	<b>EX●</b>	1690	JR78-15B Radial White Stripe	<b>EX●</b>	—

● JR78-15B Radial spare tire must be ordered.



# 1977 CHEVY VAN GVWR SELECTOR

GVW Rating (lbs)	†GAWR (lbs)		Minimum Equipment Required for GVW Rating			
	Front	Rear	Tire Capacity (lbs ea)		Chassis Equipment	
			Front	Rear		

## G30 SERIES (110" WB only)

GVW Rating (lbs)	Front GAWR (lbs)	Rear GAWR (lbs)	Front Tire Capacity (lbs ea)	Rear Tire Capacity (lbs ea)	Chassis Equipment
6400	3400	3460	1730	1730	Standard
6900	3400	3980	1990	1990	
7100	3400	4200	2350	2350	
7700	3900	4700	2350	2350	HD Front Springs (F60); HD Rear Springs (G50); HD Power Brakes (J55)
● 8100	3900	5360	2680	2680	HD Front Springs (F60); HD Rear Springs (G50); HD Power Brakes (J55); Stabilizer Bar (F59)

## G30 SERIES (125" WB only)

GVW Rating (lbs)	Front GAWR (lbs)	Rear GAWR (lbs)	Front Tire Capacity (lbs ea)	Rear Tire Capacity (lbs ea)	Chassis Equipment
6600	3400	3460	1730	1730	Standard
7100	3400	3980	1990	1990	
7400	3400	4200	2350	2350	
7900	3900	4700	2350	2350	HD Front Springs (F60); HD Rear Springs (G50); HD Power Brakes (J55)
● 8400	3900	5360	2680	2680	HD Front Springs (F60); HD Rear Springs (G50); HD Power Brakes (J55); Stabilizer Bar (F59)

†GAWR's shown are the maximum for each axle with equipment listed. Other GAWR's are available, and they are determined as the minimum capacity of either axle, springs or tires.

● V8 models only.

## FRONT AND REAR TIRE AVAILABILITY CHART

### G30 SERIES

Spare tire to match either front or rear tires is available at extra cost

FRONT			REAR			
Capacity (lbs ea)	Description	Option Number	Capacity (lbs ea)	Description	Option Number	
		Highway			Highway	On-Off Road
1730	8.00-16.5C	SC	1730	8.00-16.5C	SC	—
1990	8.75-16.5C	TC	1990	8.75-16.5C	TC	—
2350	8.75-16.5D	TE	2350	8.75-16.5D	TE	TF
2350	8.75-16.5D White Stripe	TM	2350	8.75-16.5D White Stripe	TM	—
2680	8.75-16.5E	TH	2680	8.75-16.5E	TH	TJ

# 1977 CHEVY SPORTVAN GVWR SELECTOR

GVW Rating (lbs)	†GAWR (lbs)		Minimum Equipment Required for GVW Rating			
	Front	Rear	Tire Capacity (lbs ea)		Chassis Equipment	
			Front	Rear		

## G10 SERIES

GVW Rating (lbs)	Front	Rear	Front	Rear	Chassis Equipment
5400 (110" WB only)	2740	2740	1370	1370	Standard
5600	2940	2940	1470	1470	

## G20 SERIES

GVW Rating (lbs)	Front	Rear	Front	Rear	Chassis Equipment
6400	3200	3380	1690	1690	Standard

†GAWR's shown are the maximum for each axle with equipment listed. Other GAWR's are available, and they are determined as the minimum capacity of either axle, springs or tires.

## FRONT AND REAR TIRE AVAILABILITY CHART

### G10 SERIES

Spare tire to match either front or rear tires must be ordered

Capacity (lbs ea)	FRONT		Capacity (lbs ea)	REAR		
	Description	Option Number		Description	Option Number	
		Highway			Highway	On-Off Road
1370	F78-15B	FP	1370	F78-15B	FP	—
1370	F78-15B White Stripe	FR	1370	F78-15B White Stripe	FR	—
1470	G78-15B	GS	1470	G78-15B	GS	GU
1470	G78-15B White Stripe	GT	1470	G78-15B White Stripe	GT	—
1470	GR78-15B Radial White Stripe	DR	1470	GR78-15B Radial White Stripe	DR	—

### G20 SERIES

Spare tire to match either front or rear tires is available at extra cost

Capacity (lbs ea)	Description	Option Number	Capacity (lbs ea)	Description	Option Number	Option Number
1690	J78-15B	JC	1690	J78-15B	JC	JA
1690	J78-15B White Stripe	JB	1690	J78-15B White Stripe	JB	—
1690	JR78-15B Radial White Stripe	EX●	1690	JR78-15B Radial White Stripe	EX●	—

● JR78-15B Radial spare tire must be ordered.



# 1977 CHEVY SPORTVAN GVWR SELECTOR

GVW Rating (lbs)	†GAWR (lbs)		Minimum Equipment Required for GVW Rating			
	Front	Rear	Tire Capacity (lbs ea)		Chassis Equipment	
			Front	Rear		

## G30 SERIES

GVW Rating (lbs)	Front GAWR (lbs)	Rear GAWR (lbs)	Front Tire Capacity (lbs ea)	Rear Tire Capacity (lbs ea)	Chassis Equipment
6600	3400	3460	1730	1730	Standard
7100	3400	3980	1990	1990	
7400	3400	4200	2350	2350	
7900	3900	4700	2350	2350	HD Front Springs (F60); HD Rear Springs (G50); HD Power Brakes (J55)
● 8400	3900	5360	2680	2680	HD Front Springs (F60); HD Rear Springs (G50); HD Power Brakes (J55); Stabilizer Bar (F59)

†GAWR's shown are the maximum for each axle with equipment listed. Other GAWR's are available, and they are determined as the minimum capacity of either axle, springs or tires.

● V8 models only.

## FRONT AND REAR TIRE AVAILABILITY CHART

### G30 SERIES

Spare tire to match front or rear tires is available at extra cost

FRONT			REAR			
Capacity (lbs ea)	Description	Option Number	Capacity (lbs ea)	Description	Option Number	
		Highway			Highway	On-Off Road
1730	8.00-16.5C	SC	1730	8.00-16.5C	SC	—
1990	8.75-16.5C	TC	1990	8.75-16.5C	TC	—
2350	8.75-16.5D	TE	2350	8.75-16.5D	TE	TF
2350	8.75-16.5D White Stripe	TM	2350	8.75-16.5D White Stripe	TM	—
2680	8.75-16.5E	TH	2680	8.75-16.5E	TH	TJ